

The Whetherly Book of Scottish Country Dances

Number 4

By John W. Mitchell

Originally published by:
Wallace Mitchell & Co., Hove, 1979

Revised and re-published by:
Alison Mitchell, 2020
alisonmwmitchell@hotmail.com

Digitalisation and editorial assistance:
Viktor Lehmann

Diagrams:
Keith Rose

Version:
1.01 / 2020-07-15

This work is licensed under the Creative Commons
Attribution-NoDerivatives 4.0 International License
(the distribution of unmodified copies of this leaflet is allowed).

To view a copy of this license, visit
creativecommons.org/licenses/by-nd/4.0/

© 2020 by Alison Mitchell

Contents

1.	After the Battle	32 bar Reel	Round Room	2C/any
2.	Ainster Fisherman	32 bar Reel	Longwise	4C/4C
3.	Anne Eltham's Fancy	32 bar Jig	Longwise	3C/4C
4.	Anne Fraser McKenzie	40 bar Jig	Longwise	3C/4C
5.	Apple Tree, The	48 bar Reel	Longwise	4C/4C
6.	Archduke John of Austria	32 bar Strathspey	Longwise	3C/4C
7.	Ardbeg	32 bar Reel	Longwise	2C/4C
8.	Black Bear, The	48 bar Reel	Longwise	3C/4C
9.	Bonawe Highlanders	32 bar Jig	Longwise	3C/4C
10.	Bonnie Brig	32 bar Strathspey	Longwise	4C/4C
11.	Bonnie Woods O'Craigielea	64 bar Reel	Longwise	3C/4C
12.	Braidley's House	32 bar Jig	Round Room	4C/any
13.	Breakdown, The	32 bar Reel	Longwise	3C/3C
14.	Brinkie Braes	48 bar Strathspey	Longwise	4C/4C
15.	Bung Your Eye	32 bar Jig	Longwise	3C/4C
16.	Caithness Volunteers	32 bar Reel	Longwise	2C/4C
17.	Cantie Auld Man	32 bar Jig	Round Room	2T/any
18.	Cecil McCausland	48 bar Jig	Longwise	3C/4C
19.	Channel Fleet	32 bar Hornpipe	Longwise	4C/4C
20.	Chinese Breakdown	48 bar Reel	Longwise	3C/4C
21.	Christie McLeod	32 bar Reel	Round Room	2C/any
22.	Christine McAskill	48 bar Jig	Round Room	2C/any
23.	Churchill Barracks	40 bar Reel	Longwise	2C/4C
24.	Clarence House	32 bar Reel	Longwise	4C/4C
25.	C. M. Beattie	32 bar Reel	Longwise	3C/4C
26.	Cockle Gatherers, The	32 bar Reel	Longwise	3C/4C
27.	Coffee Leaf, The	40 bar Reel	Longwise	4C/4C
28.	Collie's Reel	192 bar Reel	Square	4C/4C
29.	Colonel Byng	32 bar Strathspey	Longwise	4C/4C
30.	Colosseum	32 bar Reel	Longwise	2C/4C
31.	Conversazione, The	32 bar Strathspey	Longwise	3C/4C
32.	Cropie's Strathspey	32 bar Strathspey	Longwise	3C/3C
33.	Dawning of the Day	32 bar Reel	Round Room	1T/any
34.	David Ross	32 bar Reel	Longwise	3C/3C
35.	Davie's Brae	32 bar Jig	Longwise	4C/4C
36.	Dornachd Head	32 bar Jig	Longwise	5C/5C
37.	Edward Jay's Jaunt	32 bar Reel	Longwise	3C/4C
38.	Ellen Richard's Delight	256 bar Jig	Square	4C/4C
39.	Eriskay Boat	32 bar Reel	Longwise	3C/5C

New formations are described in the appendix of this book:

- Quern progression for two couples (Brinkie Braes)
- Quern progression for three couples (Anne Eltham's Fancy)

Original Introduction

In order to reduce costs and enable the dances to be produced in a reasonably legible fashion, this collection has been duplicated instead of being printed. Due to other commitments typing has been held up, which has in turn delayed publication. It is hoped that books number 5 & 6 will soon be available. The dances are already devised and merely require to be written up. Once again I hope to have produced a variety of simple and not so simple dances involving both old and new figures.

John W. Mitchell (1979)

Introduction to the new edition

Whilst the alphabetical order of the original publication has been retained, each dance has been rendered onto a single page with no page numbers given. This is in order to enable easy printing of individual dances, especially for those who only wish to dance one dance at a time. The omission of page numbers is not expected to cause problems as long as the reader is reasonably familiar with the alphabet.

The majority of these dances are named after the original tunes – I am not aware of any dedications, although further information would be welcome if someone can remember why these dances were written in the first place.

Almost 40 years after the original publication, it is still hoped that book number 5 (the new edition) will soon be available. The tone of the introduction is kept as close as possible to the tone of the original author, my father John W. Mitchell, who seemed not to know when people had had enough and wrote 828 dances before he presumably either ran out of tunes or, judging by the approximate publication dates of 1967-1991, I started to get in the way.

Please enjoy a tour through Whetherly Book No. 4.

Alison M. W. Mitchell (2020)

John Wallace Mitchell - A Brief Biography

(31/05/1931 – 25/11/2012)

John Wallace Mitchell was born and raised in Brighton & Hove, Sussex. Following his school education, which took place against a background of war, he completed military service from 1949-1951 with the Royal Electrical and Mechanical Engineers (REME) army division. He then started work in accountancy, joining the Sperry Rand corporation in 1957 as a computer and business systems analyst. In 1958 he became a member of the British Computer Society, only a few months after its foundation. In the early 1960's, the focus of his career moved towards management consultancy, and he completed many assignments for several companies, often helping to set up their first computer systems, with work taking him to many locations both within the UK and western Europe, as well as to Saudi Arabia. Eventually he set up a private practice in 1972.

He was a keen cyclist, active in several clubs and competing at a local level from 1946 – 1956. When in the army, he would often cycle back to Brighton on free weekends, which could be up to 140 miles each way.

Although he first encountered Scottish Country Dancing in Dollar, Scotland in 1947, it wasn't until 1964 that he began to take it seriously, when he joined the Leeds clubs and RSCDS Branch. After moving back to the Brighton area, he became a member of the London branch in 1966 and in 1967 was the founder chairman of the Sussex Association of Scottish Societies, which was formed to ensure the future of the local Annual Scottish Charity Ball by connecting many clubs in the region. This led to the first day schools and teachers' training courses in the region. In 1972 he obtained a full RSCDS teacher's certificate and in 1975 became the founder chairman of the Hangleton Scottish Country Dance Club. From approximately 1968 to 1992 he devised some 828 dances, which were published in this series of Whetherly Books and Sheets. Whetherly is the maiden name of his paternal grandmother, after which the house in which he grew up was also named ("Whetherly House"). In 2010 he received the London Branch award for services to Scottish Dancing.

John passed away in 2012 after a two year battle with cancer.



After the Battle

A thirty-two bar Reel for two couples in a circle formation, first couple facing clockwise round the room and second couple facing anticlockwise, each man with his partner on his right.

- 1-8 Four hands round to the left in a circle and back to the right.
- 9-12 The men turn three quarters with the left hand and join right hands with opposite lady, then all balance in line.
- 13-16 Releasing left hands the men turn opposite lady half way with the right hand to change places, the ladies join left hands and all balance in line.
- 17-24 Releasing hands and passing by the right shoulder to start the two couples dance a reel of four.
- 25-28 All join hands and balance in line, releasing right hands the ladies turn half way with the left hands to change places and join right hands with their own partners.
- 29-32 All balance in line, then turn own partner with the right hand to finish with the lady on her partners right, backs to the couple with whom they have just danced. All are now facing in the same direction as previously and facing a new couple ready to repeat the dance.

Repeat as often as desired.

Recommended tune: After the Battle

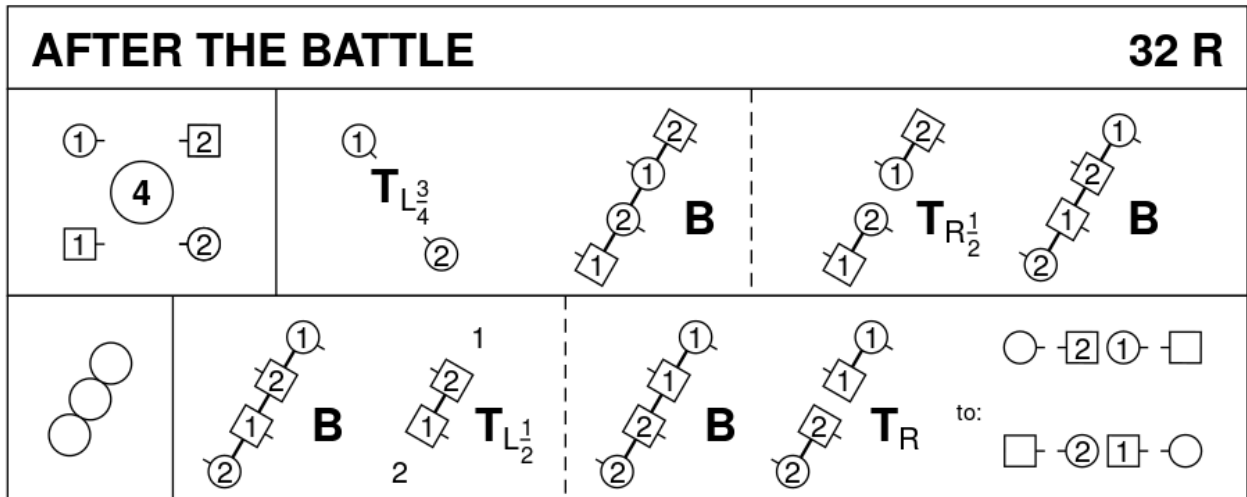

Ainster Fisherman

A thirty-two bar Reel for four couples in a longwise set.

- 1-4 First and second couples dance right hands across in a wheel.
- 5-8 First, second and third couples dance a half a reel of three on own side of the set, firsts and seconds pass by the right to commence.
- 9-12 Third and second couples dance right hands across in a wheel, first and fourth couples do the same.
- 13-16 All four couples dance a half a reel of four on own sides of the set, passing by the right shoulder to commence.
- 17-20 All four couples join both hands with partner and slip down the middle. Fourth couple to finish at original position.
- 21-24 First, second and third couples slip up the middle to original places, passing under an arch made by fourth couple.
- 25-32 First couple cast off into second place, cross over giving right hands in passing, cast off into third place, cross over giving left hand in passing and cast off into fourth place on own side.

Repeat with new top couple.
 Recommended tune: Ainster Fisherman

Editor's note to the 2020 edition

The original description for bars 25-32 is vague on phrasing. The editors assume that John intended a 3-3-2 movement (3 bars to cast and cross right hand, another 3 bars to cast and cross left hand, then 2 bars to cast to the bottom), allowing couples 2, 3 and 4 for a joint step up on bars 31 & 32.

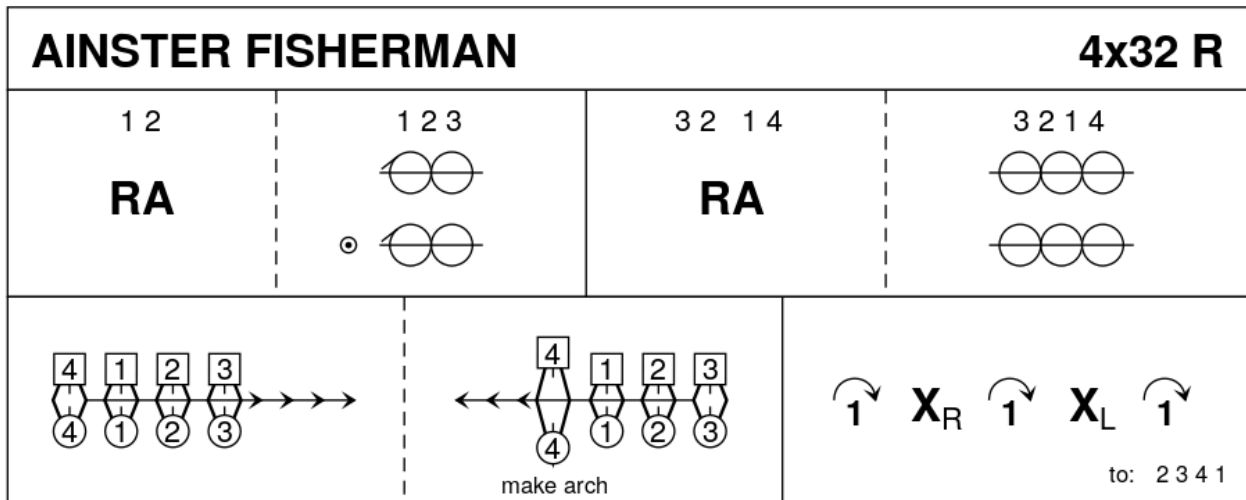

Anne Eltham's Fancy

A thirty-two bar Jig for three couples in a four couple longwise set.

- 1-4 First couple dance down the middle with nearer hands joined, cast around third couple into second place, second couple step up on bars 3 & 4.
- 5-8 First couple, followed by second couple, dance down the middle with nearer hands joined, cast around third couple. First couple finishing in first place, second couple finishing outside second place facing up.
- 9-10 The couple in first place dance down the middle into third place, the couple outside second place dance up into first place and the couple in third place cast up to finish outside the sidelines opposite second place.
- 11-12 All three couples set.
- 13-16 Repeat bars 9-12 from new places.
- 17-24 Third, first and second couples dance a Quern progression*.
- 25-32 Second, first and third couples dance six hands round in a circle to the left and back to the right.

Repeat from second place.

Recommended tune: Anne Eltham's Fancy

* The Quern progression for 2 and 3 couples is described in the appendix of this book.

Editor's note to the 2020 edition

The original description led to an incorrect order at the end of bar 8, preventing progression. Bars 1-8 have been slightly changed for the 2020 edition. The original version of bars 1-8 is included here for completeness:

- 1-4 First couple lead down between second and third couples, second couple step up, cross over and cast up into second place on the opposite side.
- 5-8 First couple lead down below third couple, cross to own side to finish outside the sidelines opposite second place.

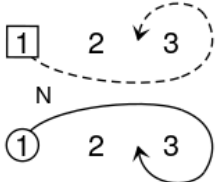
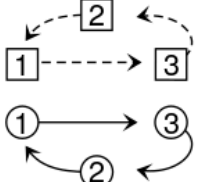
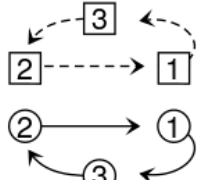
ANNE ELTHAM'S FANCY			8x32 J
			ALL S
	ALL S	Quern Progression 3 1 2 3 1 2 2x 1x 3x T_R RA X_R 3 bars 3 bars	2 1 3 6





Anne Fraser McKenzie

A forty bar Jig for three couples in a four couple longwise set.

- 1-4 Second couple lead up to the top, between first couple, cross over and cast off into second place on the opposite side.
- 5-8 Second and first couples dance half rights and lefts.
- 9-16 Second and first couples dance a ladies' chain.
- 17-20 First man turns third lady with the right hand once round whilst first lady turns third man similarly.
- 21-24 Second, first and third couples dance a half reel of three on the sides; to commence second lady passes first man by the left shoulder and second man passes first lady by the left shoulder.
- 25-28 First man turns second lady with the right hand once round, whilst first lady turns second man similarly; note: second couple are in third place.
- 29-32 Third, first and second couples dance a half reel of three on the sides of the set; to commence first man and third lady pass by the left shoulder and first lady and third man pass by the left shoulder.
- 33-38 Second, first and third couples dance six hands round to the left in a circle.
- 39-40 First couple cross to own side giving right hand in passing.

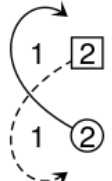
Repeat from second place.

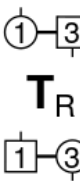
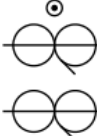
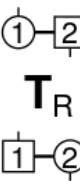
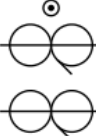
Recommended tune: Anne Fraser McKenzie

ANNE FRASER McKENZIE						8x40 J	
	1 2x RL	2 1x 	 T_R	2 1x 3 	 T_R	3 1x 2 	 6 bars

The Apple Tree

A forty-eight bar Reel for four couples in a longwise set.

- 1-8 All four couples join hands on the sides, fourth couple also join hands. First man dances under an arch made by first and second ladies, casts off to the foot of the set, crosses over and up on the men's side to his original place, using slip step, the other dancers all follow until second lady turns under the arch on bar eight: first lady does not move.
- 9-16 First lady dances under the arch made by first and second men, casts off, crosses and dances up to her original place, using slip step, the other dancers all follow until second man turns under the arch.
- 17-18 First couple cross over passing by the right shoulder.
- 19-24 First man passes second lady by the right shoulder to commence a reel of three on the opposite side with second and third ladies, first lady passes second man by the left shoulder to commence a reel of three with second and third men.
- 25-26 First couple cross to own side passing by the right.
- 27-32 First, second and third ladies dance a reel of three on the side; first and second ladies passing by the right to start. First, second and third men dance a reel of three on the side, first and second men passing by the left to start.
- 33-34 All join hands on the side and set.
- 35-40 All four couples cast off, fourth couple followed by third, second and first couples lead up the middle.
- 41-48 First couple stop in fourth place. Fourth couple followed by third and second couples cast off below fourth place. Fourth couple lead up between first couple into third place; third couple, following fourth couple, dance up between first couple and continue to dance up between fourth couple into second place; second couple, following third couple, dance up between first, fourth and third couples to finish in first place.

Repeat with new top couple.

Recommended tune: The Apple Tree

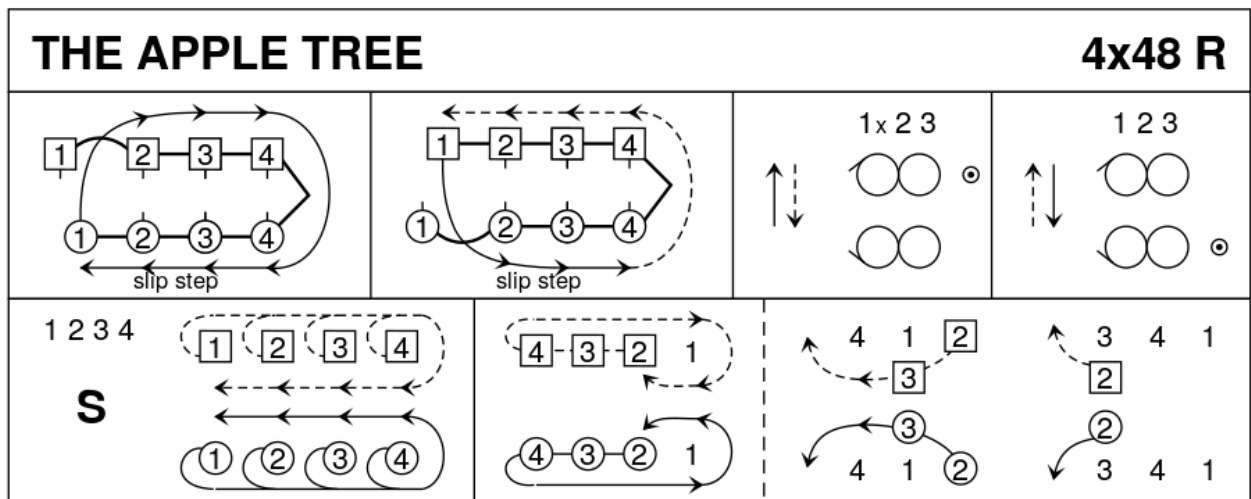









Archduke John of Austria

A thirty-two bar Strathspey for three couples in a longwise set.

- 1-4 The couple in first place cross over to second place on the opposite side giving right hand in passing, the couple in second place cross over to the third place on the opposite side giving left hand in passing and the couple in third place cast up to first place on the same side; all join hands and set.
- 5-8 Repeat bars 1-4 from new positions.
- 9-12 Repeat bars 1-4 from new positions, all are now back in their original places.
- 13-16 First and second couples dance right hands across in a wheel.
- 17-24 First and second couples change places with a knot.
- 25-28 First and second couples dance left hands across in a wheel.
- 29-32 First and third couples dance rights and lefts, one step to each hand.

Repeat from second place.

Recommended tunes: Archduke John of Austria

ARCHDUKE JOHN OF AUSTRIA				8x32 S			
1 2 3 3 1x 2x    S	3 1x 2x 2x 3x 1    S	2x 3x 1 1 2 3    S		1 2 RA	1 2 KNOT	2 1 LA	1 3 RL 1 bar / hand

Ardbeg

A thirty-two bar Reel for two couples in a longwise set.

- 1-4 First man and second lady set and change places giving right hands in passing.
- 5-8 First lady and second man set and turn with the left hand to finish back to back in the centre of the dance, first lady facing up and second man facing down; meanwhile first man and second lady dance round the outside of their partners in a clockwise circle, slightly more than half way to finish facing their own partners, first man at the top facing down and second lady at the foot facing up.
- 9-16 First and second couple pass own partner by the right shoulder to commence a reel of four up and down the set.
- 17-24 First and second couples dance an Inverted Knot to progress, commencing by turning three quarters with the right hand to face up the dance in an allemande hold, first couple cast off on the men's side into second place, second couple following; then the two couples turn with the left hand to finish on the opposite side of the dance (men on the ladies' side and ladies on the men's side).
- 25-28 Second couple lead down below first couple, cross over and cast up into first place on own side.
- 29-32 First couple lead up between second couple, cross over and cast off into second place on own side.

Repeat from second place.
 Recommended tune: Ardbeg

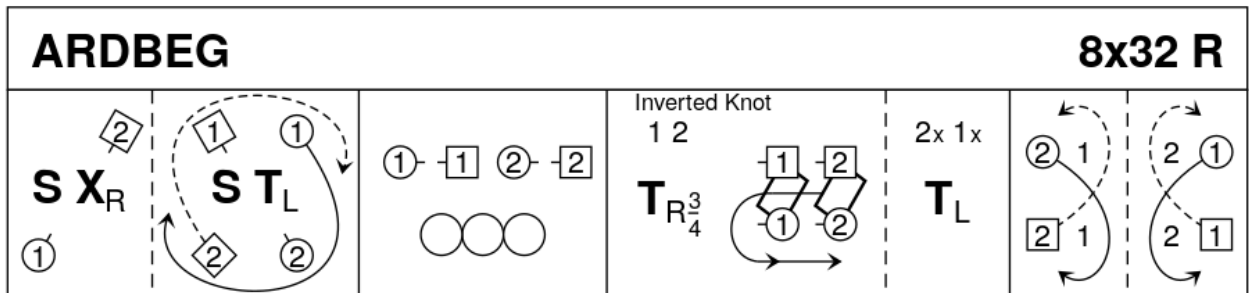





The Black Bear

A forty-eight bar Reel for three couples in a four couple longwise set.

- 1-6 First and second couples dance right hands across for three bars and back with the left hand across for three bars.
- 7-8 First couple cross over giving left hand to finish facing first corners. Meanwhile second couple cast up into first place.
- 9-12 First couple dance a half reel of four with their first corners, to finish facing second corners.
- 13-16 First couple dance a half reel of four with their second corners, to finish facing first corners on the opposite side of the set.
- 17-20 First couple set to their first corners, coupé pas de basque, then change places giving right hands with two skip change of step commencing with the left foot.
- 21-24 First couple and first corners set coupé pas de basque commencing with the left foot, then change places giving right hand with two skip change of step commencing right foot; first couple finish facing second corners.
- 25-32 Repeat bars 17-24 with second corners. On bars 31-32 the dancing couple dance into second place on own side whilst second corners dance back to their positions on the opposite sides.
- 33-36 First couple dance half rights and lefts with their first corners to get first corners back to own sides.
- 37-40 First couple dance half rights and lefts with their second corners to get second corners back to own sides.
- 41-48 Second, first and third couples dance six hands round in circle to the left for four bars and back to the right.

Repeat from second place.

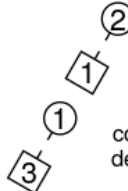
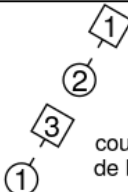
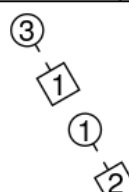
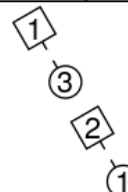
Recommended tune: The Black Bear

THE BLACK BEAR			8x48 R
<p style="text-align: center;">1 2 1 2 1 2</p> <p style="text-align: center; font-size: 1.2em;">RA LA</p> <p style="text-align: center; font-size: 0.8em;">3 bars 3 bars</p>			<div style="display: flex; justify-content: space-around; align-items: center;"> <div style="text-align: center;">  <p>S</p> <p style="font-size: 0.8em;">coupé pas de basque</p> </div> <div style="text-align: center;"> <p>X_R</p> <p style="font-size: 0.8em;">left foot</p> </div> </div>
<div style="display: flex; justify-content: space-around; align-items: center;"> <div style="text-align: center;">  <p>S</p> <p style="font-size: 0.8em;">coupé pas de basque left</p> </div> <div style="text-align: center;"> <p>X_R</p> <p style="font-size: 0.8em;">right foot</p> </div> </div>	<div style="display: flex; justify-content: space-around; align-items: center;"> <div style="text-align: center;">  <p>S</p> <p style="font-size: 0.8em;">coupé pas de basque</p> </div> <div style="text-align: center;"> <p>X_R</p> <p style="font-size: 0.8em;">left foot</p> </div> </div>	<div style="display: flex; justify-content: space-around; align-items: center;"> <div style="text-align: center;">  <p>S</p> <p style="font-size: 0.8em;">coupé pas de basque left</p> </div> <div style="text-align: center;">  <p style="font-size: 0.8em;">1 → 2 3 ← 1</p> </div> </div>	
<div style="display: flex; justify-content: space-around; align-items: center;"> <div style="text-align: center;"> <p style="font-size: 1.2em;">RL</p> </div> </div>	<div style="display: flex; justify-content: space-around; align-items: center;"> <div style="text-align: center;"> <p style="font-size: 1.2em;">RL</p> </div> </div>	<p style="font-size: 1.2em;">2 1 3</p> <div style="border: 1px solid black; border-radius: 50%; width: 40px; height: 40px; margin: 0 auto; display: flex; align-items: center; justify-content: center;"> <p style="font-size: 1.5em; margin: 0;">6</p> </div>	

Bonawe Highlanders

A thirty-two bar Jig for three couples in a four couple longwise set.

- 1-8 First couple lead down between second couple and out to the ladies' side between second and third ladies, first lady casts up and first man cast off; first couple meet and lead out between second and third men, first lady casts up and first man casts off; first couple meet in the middle and turn with the right hand to finish facing their first corners. Second couple step up on bars 1 & 2.
- 9-12 First couple turn first corners with the left hand to finish first man between third couple facing down and first lady between second couple facing up.
- 13-14 First man casts up behind third man into second place on own side, whilst first lady casts off behind second lady into second place on own side.
- 15-16 First couple turn with the left hand to face their second corners.
- 17-20 First couple turn their second corners with the right hand to finish with first man between second couple facing up and first lady between third couple facing down.
- 21-22 First man casts off behind second man into second place on own side, whilst first lady casts up behind third lady into second place on own side.
- 23-24 First couple turn three quarters with the right hand, to finish with first lady facing up and first man facing down.
- 25-30 First couple dance a reel of three on the sides with their corners, passing first corner by the left shoulder to start.
- 31-32 First couple cross back to second place on own side giving right hand in passing.

Repeat from second place.

Recommended tune: Bonawe Highlanders

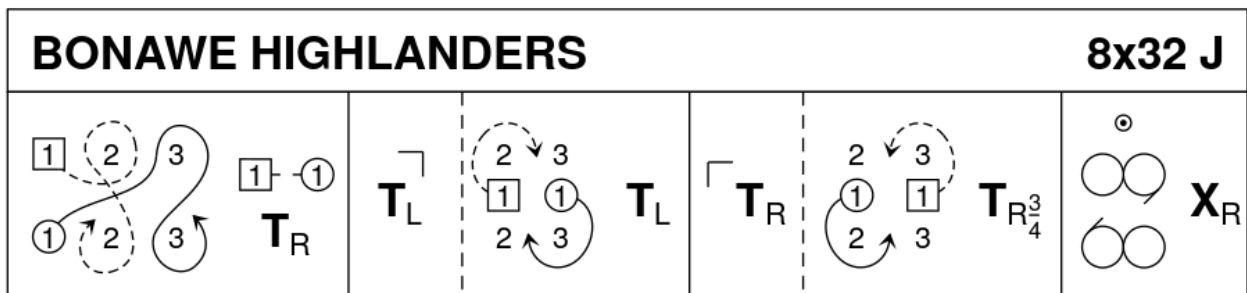

Bonnie Brig

A thirty-two bar Strathspey for four couples in a longwise set.

- 1-4 First and fourth couples face up and down the set, join nearer hand with partner and advance for two steps to meet, then set facing up and down the set. Meanwhile second and third couples join hands on the side and retire for two steps, releasing hands second couple advance diagonally into first place on own side whilst third couple advance diagonally into fourth place on own side.
- 5-8 First and fourth couples dance right hands across in a wheel: at the same time second and third couples turn own partner once with the right hand.
- 9-12 Second and first couples dance left hands across in a wheel to finish on own sides facing up and down the set, fourth and third couples do the same.
- 13-16 All set with Highland Schottische step.
- 17-24 All pass the person they are facing by the right shoulder to commence reels of four on own side of the set.
- 25-32 First, fourth and third couples dance a knot to bring first couple into fourth place.

Repeat with a new top couple.
 Recommended tune: Bonnie Brig

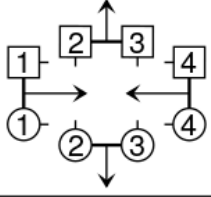
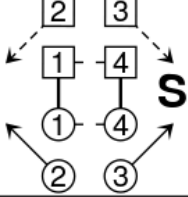
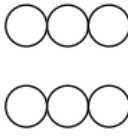
BONNIE BRIG		4x32 S	
		$\overbrace{2 \quad 1 \quad 4 \quad 3}$ T_R RA T_R	2 1 4 3 LA
$\overline{2} \quad \overline{1} \quad \overline{4} \quad \overline{3}$ HS $\textcircled{2} \quad \textcircled{1} \quad \textcircled{4} \quad \textcircled{3}$		$1 \quad 4 \quad 3$ KNOT to: 2 3 4 1	

The Bonnie Woods O’Craigielea

A sixty-four bar Reel for three couples in a four couple longwise set.

- 1-8 First couple set, cast off into second place, second couple step up on bars 3 & 4. First couple lead up crossing over between second, couple and cast off into second place on the opposite side.
- 9-12 First and third couples face up and down, and dance back to back, second couple dance back to back at the same time.
- 13-16 Second couple turn one and a half times with the right hand to change places and finish facing up the set with right hand joined. First man and third lady turn similarly to finish facing out on the ladies’ side, first lady and third man turn similarly to finish facing out on the men’s side.
- 17-20 All lead out for two steps, turn and lead in to finish with second and third couples facing up and down on the sides and first couple facing across in third place.
- 21-24 Second and third couples dance back to back on the sides, first couple also dance back to back.
- 25-28 First couple turn one and a half times with the right hand to change places and finish facing down the set; second man and third lady turn similarly and finish facing out on the ladies’ side; second lady and third man turn and finish facing out on the men’s side.
- 29-32 All lead out for two bars, turn and dance in to finish with third couple facing across in first place and second and first couples facing up and down on the sides,
- 33-36 Third couple dance back to back, first and second couples dance back to back on the sides.
- 37-40 Third couple turn one and a half times with the right hand and finish facing up with right hands joined; first lady and second men do the same to finish facing out on the ladies’ side; whilst first man and second lady do the same to finish facing out on the men’s side.
- 41-44 All lead out for two bars turn and dance in to finish on the side lines; with third couple in first place on the opposite side, first couple in second place on own side and second couple in third place on the opposite side.
- 45-48 First couple turn with the left hand one and a half times to face first corner position.
- 49-52 First couple dance a half a reel of four with their first corners and finish facing their second corners.
- 53-56 First couple dance a half reel of four with their second corners and finish in second place on own side of the set.
- 57-64 Second, first and third couples dance six hands round in a circle to the left and back to the right.



Repeat from second place.

Recommended tune: The Bonnie Woods O’Craigielea

Note

To get to the bottom from third place original first couple should set and cast off on the first four bars of the next repeat.

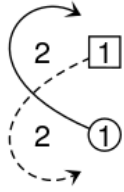
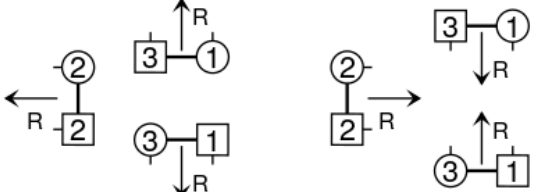
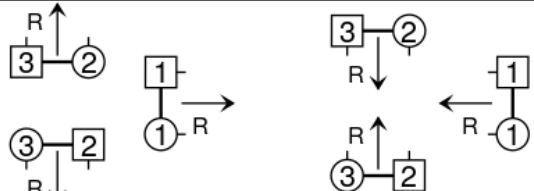
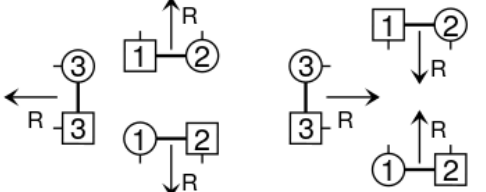
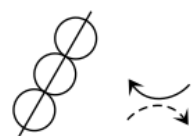
(diagram on next page)

THE BONNIE WOODS O' CRAIGIELEA			8x64 R	
S 		D $\begin{matrix} \boxed{2} & \textcircled{1} & \textcircled{3} \\ \textcircled{2} & \boxed{1} & \textcircled{3} \end{matrix}$	T _{R1¹/₂} $\begin{matrix} \boxed{2} & \textcircled{1} & \textcircled{3} \\ \textcircled{2} & \boxed{1} & \textcircled{3} \end{matrix}$	
	D $\begin{matrix} \textcircled{2} & \textcircled{3} & \textcircled{1} \\ \boxed{2} & \textcircled{3} & \boxed{1} \end{matrix}$	T _{R1¹/₂} $\begin{matrix} \textcircled{2} & \textcircled{3} & \textcircled{1} \\ \boxed{2} & \textcircled{3} & \boxed{1} \end{matrix}$		
	D $\begin{matrix} \boxed{3} & \textcircled{2} & \textcircled{1} \\ \textcircled{3} & \boxed{2} & \textcircled{1} \end{matrix}$	T _{R1¹/₂} $\begin{matrix} \boxed{3} & \textcircled{2} & \textcircled{1} \\ \textcircled{3} & \boxed{2} & \textcircled{1} \end{matrix}$		
	T _{L1¹/₂}			2 1 3 6

Braidley's House

A thirty-two bar Jig for four couples, in a circle round the room. First and third couples facing clockwise and second and fourth couples facing anticlockwise, first and second couples are on the outside of the circle with third and fourth couples inside, each man with his partner on his right.

- 1-4 First man and second lady advance and retire, third lady and fourth man do the same. Meanwhile their partners dance right hands across in a wheel and finish facing out.
- 5-8 First man, second lady, third lady and fourth man dance left hands across in a wheel. Meanwhile first lady, second man, third man and fourth lady cast into their partners original places and advance and retire. All finish in own partner's original place.
- 9-16 First and second couples dance a ladies' chain, third and fourth couples do the same.
- 17-24 All set twice to own partner, then turn partner with two hands using pas de basque step.
- 25-28 All pass own partner by the right shoulder to commence a half reel of four, finish with third and fourth couples on the outside and first and second couples on the inside of the circle, each man with his partner on his right.
- 29-32 All join hands and set, then change places with the person opposite giving right hand in passing. Finish with first and third couples still facing clockwise and second and fourth couples facing anticlockwise. Each line having its back to the line it has just passed.

Repeat as many times as desired.
Recommended tune: Braidley's House

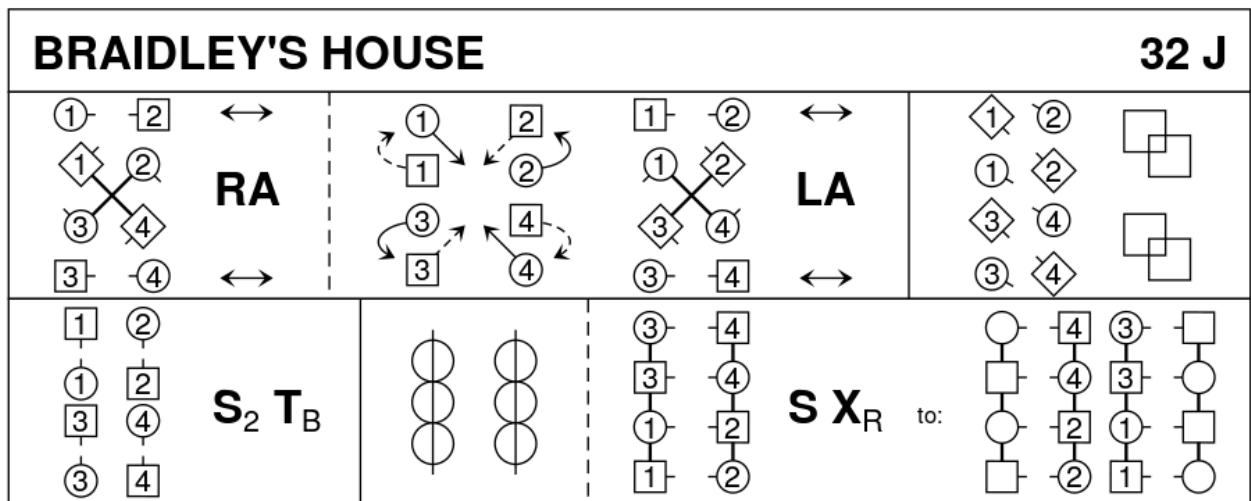

The Breakdown

A thirty-two bar Reel for three couples in a three couple longwise set.

- 1-8 First lady dances a figure of eight round second and third ladies, passing second lady by the right to start and finishing facing out. At the same time first man dances a figure of eight round second and third men passing second man by the right to start.
- 9-12 First lady casts off below third lady and dances up in front of her, whilst first man chases his partner behind second lady and dances in between second and third ladies to face up.
- 13-16 First man dances up and casts off behind second and third men then dances in to face third lady. Meanwhile first lady chases her partner behind second man and dances in between second and third men to face second lady.
- 17-24 First lady dances a reel of three across the set with second couple passing second lady by the right to start, at the same time first man dances a reel of three across the set with third couple passing third lady by the right to start.
- 25-28 First couple dance right hands across in a wheel with second and third ladies.
- 29-30 First couple dance left hands across in a wheel half way with second and third men.
- 31-32 Second and third ladies step up. Releasing hands first lady dances across into third place on the ladies' side of the set, first man dances down into third place on own side, third man follows first man into second place on own side and second man dances up into first place on own side.

Repeat with new top couple.

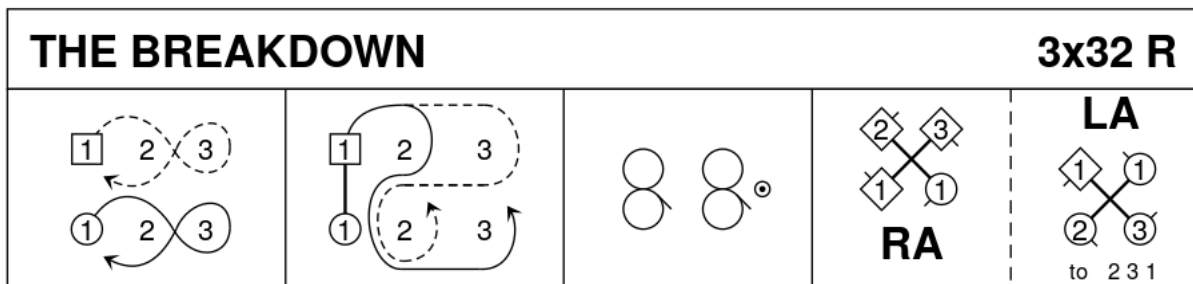

Brinkie Braes

A forty-eight bar Strathspey for four couples in a four couple longwise set.
On the second chord third and fourth couples cross to the opposite side of the set.

- 1-2 Second and third couples dance right hands across in a wheel half way.
- 3-6 First and third couples dance left hands across in a wheel, second and fourth couples do the same.
- 7-8 Third and second couples dance right hands across in a wheel half way.
- 9-16 First and second couples dance a Quern progression*, third and fourth couples do the same.
- 17-24 All four couples dance eight hands round in a circle to the left for four bars, and back to the right.
- 25-32 First and fourth couples dance a ladies' chain; they finish facing up and down the set.
- 33-40 First and fourth couples set; dance half rights and lefts to change places, giving right hands on the side to start; then set, once again facing up and down on the sides.
- 41-48 All four couples dance a grand chain, one step to each hand.

Repeat with a new top couple.
Recommended tune: Brinkie Braes

* The Quern progression for 2 and 3 couples is described in the appendix of this book.

BRINKIE BRAES			3C & 4C cross on 2nd chord			4x48 S
2 3x 1 3 2x 4x 3 2x			Quern Progression 1 2 3x 4x 1 2 3x 4x 2x 1x 4 3			2 1 4x 3x
RA LA RA			T_R	RA	X_R	(8)
3 bars			3 bars			
1 4x 	<div style="display: flex; justify-content: space-around; align-items: center;"> 1 - 4 </div> <div style="font-size: 1.5em; font-weight: bold; margin: 5px 0;">S RL S</div> <div style="display: flex; justify-content: space-around; align-items: center;"> 1 - 4 </div>		<div style="display: flex; justify-content: space-around; align-items: center;"> 2 4 - 1 3 </div> <div style="font-size: 1.5em; font-weight: bold; margin: 5px 0;">CHAIN</div> <div style="display: flex; justify-content: space-around; align-items: center;"> 2 4 - 1 3 </div>			

Bung Your Eye

A thirty-two bar Jig for three couples in a four couple longwise set.

- 1-4 First lady dances half a reel of three with second couple, passing second man by the right shoulder to commence.
- 5-8 First lady collects her partner in a promenade hold and commences to dance a half reel of three with second couple, at the end of bar six she releases her partner and casts off behind third lady whilst first man completes the half reel to finish in first place on the ladies' side.
- 9-16 First lady dances a reel of three with third couple, passing third man by the left shoulder to start, meanwhile first man crosses down between second couple on bars 9 & 10 and joins his partner in a promenade hold to complete the reel with her. First couple finish below third couple facing up the centre of the set.
- 17-24 First couple lead up between third couple crossing to own side of the set, cast up to the top behind second couple; lead down between second and third couples, then cast up into second place on own side. Second couple step up on bars 23 & 24.
- 25-32 Second, first and third couples dance six hands round in a circle to the left for four bars, and back to the right.

Repeat from second place.

Recommended tune: Bung Your Eye

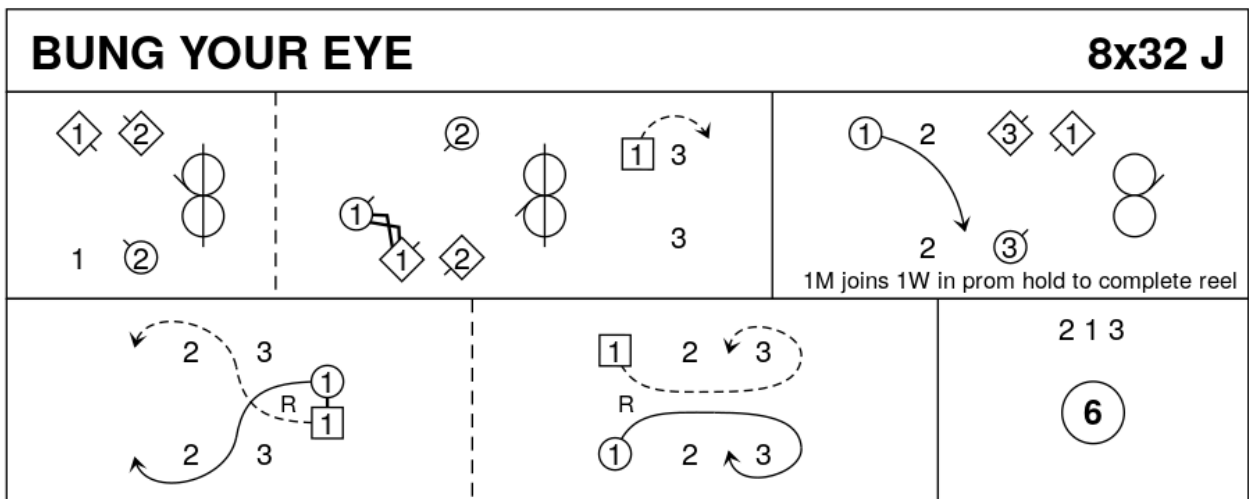

Caithness Volunteers

A thirty-two bar Reel for two couples in a longwise set.

- 1-8 First lady dances a figure of eight round second couple, passing second man by the right shoulder to start. Meanwhile first man crosses over, casts off behind second lady, crosses back to own side and casts up into his original place.
- 9-16 First man dances a figure of eight round second couple, passing second lady by the left shoulder to start. Meanwhile first lady crosses over, casts off behind second man, crosses back to own side and casts up into her original place.
- 17-24 First couple followed by second couple, who dance up to follow, dance down the middle with nearer hands joined: first couple lead up the middle with right hand under an arch made by second couple, second couple lead up behind first couple.
- 25-32 First and second couples dance an allemande to change places.

Repeat from second place.

Recommended tune: Caithness Volunteers

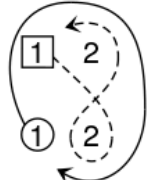
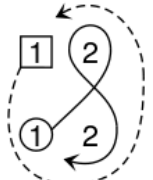
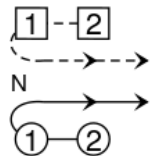
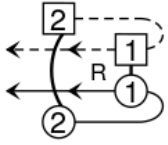
CAITHNESS VOLUNTEERS				8x32 R
				1 2 A

Cantie Auld Man

A thirty-two bar Jig for two trios, each comprising a man and two ladies, in a circle round the room. First trio are facing clockwise, and second trio anticlockwise, the men in the centre of each line.

- 1-8 The two trios dance six hands across in a right hand wheel for four bars and back with the left hand.
- 9-12 Each man turns the lady on his right with the left hand once round.
- 13-16 Each man turns the lady on his left with the right hand once round.
- 17-22 Each man passes the lady on his right by the left shoulder to start a reel of three with his partners.
- 23-24 Each man turns the lady on his right three quarters with the left hand to finish facing the opposite lady.
- 25-30 Each man passes the opposite lady (the other man's left hand partner) by the right shoulder to commence a reel of three with her and his own original right hand partner.
- 31-32 Each man finishes the reel by dancing out between the opposite ladies, thus first man finishes between second mans partners and vice versa. The men continue facing in the same direction, the ladies turning to face in the same direction as their new partner. Thus first men still face clockwise and second men anticlockwise.

Repeat with new partners as often as desired.

Recommended tune: Cantie Auld Man

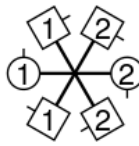
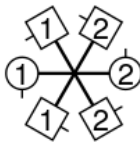
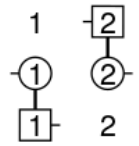
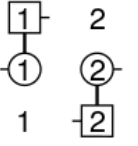
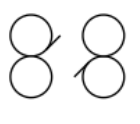
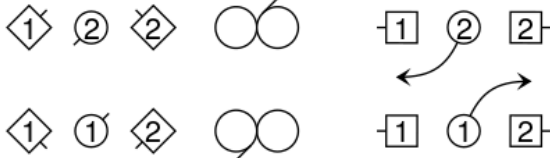
CANTIE AULD MAN		32 J	
 RA	 LA	 T_L	 T_R
 T_L^{3/4}			



Cecil McCausland

A forty-eight bar Jig for three couples in a longwise set.

- 1-4 First lady and second man set to each other and turn with the right hand.
- 5-8 First man and second lady set to each other and turn with the left hand to finish back to back with the lady facing the top of the set and first man facing down. Meanwhile first lady and second man dance round the outside in a clockwise direction to finish facing own partner, up and down the set.
- 9-16 First and second couples dance a reel of four up and down the set, on the last two bars they dance out to finish with second couple in first place and first couple in second place, both couples on the opposite sides.
- 17-20 First and second couples dance half rights and lefts.
- 21-24 First couple lead down below second couple, cross over and cast up into first place on the opposite side.
- 25-32 First and second couples dance a ladies' chain.
- 33-38 First couple lead down the middle for three bars, then lead up to finish in first place on the opposite side facing out.
- 39-40 First man turns second lady half way with the right hand to change places. Meanwhile first lady turns second man half way with the left hand to change places.
- 41-46 First couple dance a reel of three on the opposite side with second and third couples, to start first man passes third lady by the left shoulder and first lady passes third man by the right shoulder.
- 47-48 First couple cross back to own side giving right hand in passing.

Repeat from second place.

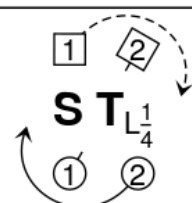
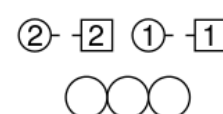
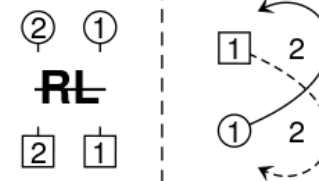
Recommended tune: Cecil McCausland

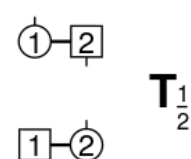
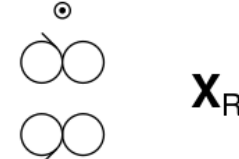
CECIL McCAUSLAND		8x48 J	
			
<p>1 x 2</p> 			

Channel Fleet

A thirty-two bar Hornpipe for four couples in a longwise set.

- 1-4 First couple crossing down between second couple to start, dance a half reel of three on the opposite side of the set with second and third couples.
- 5-8 First couple pick up fourth couple in a promenade hold, first man takes fourth lady on his left and first lady takes fourth man on her right. They dance a half reel of three on the sides of the set with second and third couples, crossing up between second couple to commence.
i.e. First couple dance Inveran Reels with second and third couples, collecting fourth couple en route.
- 9-16 First and fourth couples repeat bars 1-4, first couple leave fourth couple in their original places and cross up between second couple to complete the figure in their original places.
i.e. Repeat the Inveran Reels to return fourth couple to their original place.
- 17-24 First couple cross over giving right hand in passing and cast off into second place on the opposite side; they turn with the left hand to finish facing first corners.
- 25-32 First couple turn corner, partner, corner, partner to finish in fourth place on own side of the dance, third and fourth couples step up on the last two bars.

Repeat with new top couple.

Recommended tunes: Channel Fleet

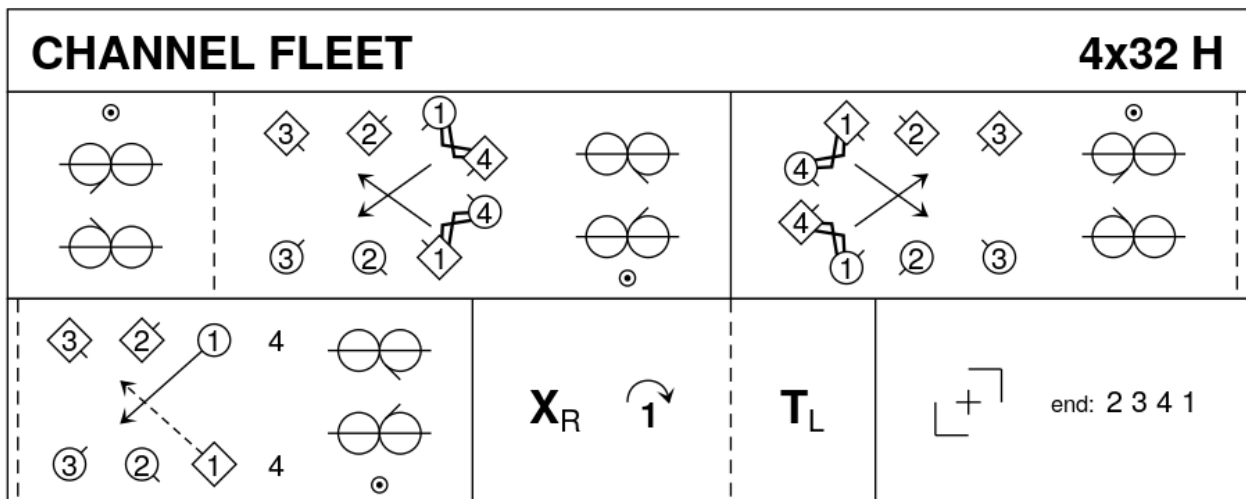

Chinese Breakdown

A forty-eight bar Reel for three couples in a longwise set.

- 1-8 First and second couples dance a reel of four, to commence first lady and second man dance in passing by the left shoulder. First couple finish in second place,
- 9-16 First and third couples dance a left shoulder reel of four, to commence first lady and third man dance in passing by the right shoulder. First couple finish in second place.
- 17-20 First lady dances right hands across with second couple whilst first man dances right hands across with third couple.
- 21-24 First lady dances left hands across with third couple whilst first man dances left hands across with second couple. First couple finish facing first corners.
- 25-26 First couple set to first corners, coupé pas de basque with right foot.
- 27-28 First couple change places with first corners with two travelling steps, commencing with the left foot.
- 29-30 First couple set to first corners, coupé pas de basque with the left foot.
- 31-32 First couple change places with their first corners giving right hand and pass by the left to finish facing their second corners.
- 33-40 Repeat bars 25-32 with second corners. On the last two steps first couple must cross into second place on own side.
- 41-48 Six hands round to the left in a circle and back to the right.

Repeat from second place.

Recommended tune: Chinese Breakdown

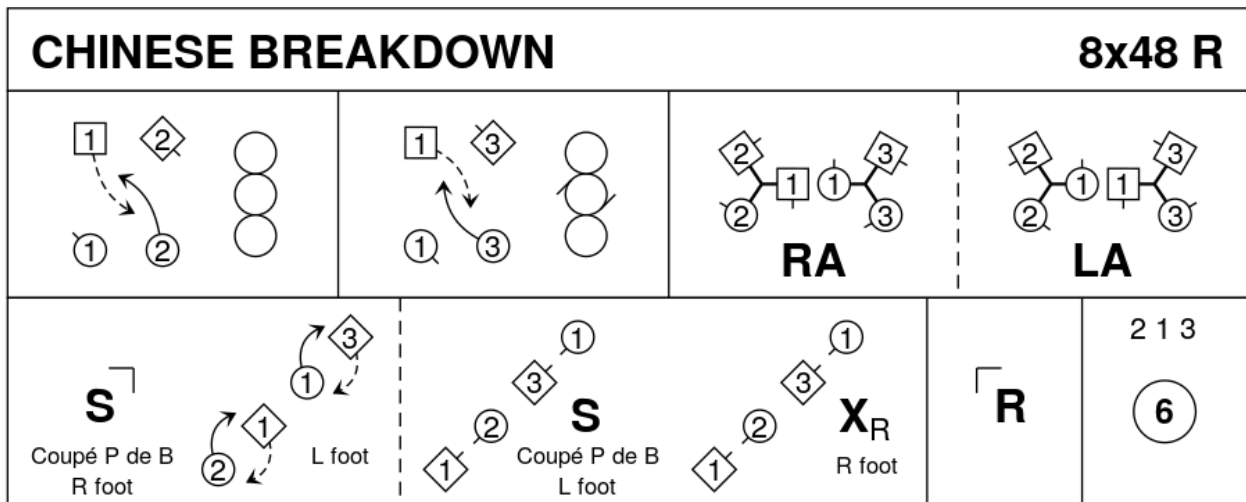

Christie McLeod

A thirty-two bar Reel for two couples in a circle round the room.

- 1-8 First and second couples dance right hands across in a wheel and back with the left hands.
- 9-10 First man and second lady change places giving right hands, first lady and second man do the same.
- 11-12 All set.
- 13-16 First and second couples dance four hands round to the right.
- 17-24 First and second couples dance a ladies' chain.
- 25-32 First and second couples dance rights and lefts, on the last two bars the men dance the polite turn to finish facing a new couple.



Repeat with new couple.

Recommended tune: Christie McLeod

Editor's note to the 2020 edition

The original version brought all lines back to their original places; there was no progression, such that both couples only change direction. Therefore, bars 11-12 have been altered. The original description follows below:

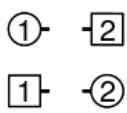
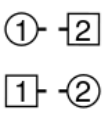
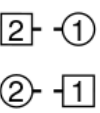
11-12 First and second couples dance four hands round to the left half way.

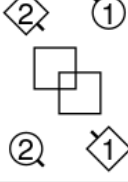
CHRISTIE McLEOD					32 R
 <p>RA</p>	<p>1 2</p> <p>LA</p>	 <p>X_R</p>	 <p>S</p>	 <p>4</p>	 <p>RL to face new couples</p>

Christine McAskill

A forty-eight bar Jig for two couples in a circle round the room.

- 1-4 First couple cross between second couple to dance a half figure of eight round them.
- 5-8 First and second couples dance half rights and lefts, giving right hand to partner to commence.
- 9-12 Second couple cross between first couple to dance a half figure of eight round them.
- 13-16 First and second couples dance half rights and lefts giving right hand to turn partner to commence.
- 17-20 First lady and second man cross between their partners to commence a half figure of eight round them.
- 21-24 First and second couples dance half rights and lefts giving right hand to opposite to commence.
- 25-28 First man and second lady cross between their partners to commence a half figure of eight round them.
- 29-32 First and second couples dance half rights and lefts giving right hand to opposite to commence. (First and second couples have now changed places from commencing positions).
- 33-36 First and second couples join nearer hands with partner and advance and retire.
- 37-40 First and second couples dance four hands round in a circle to the left to finish facing own partner.
- 41-44 First and second couples dance in to pass partner by the right shoulder, turn to face partner and retire to partners place.
- 45-48 First and second couples dance four hands round in a circle to the right. On bar 48 they all release hands and turn right about to finish facing a new couple.

Repeat with new couple.

Recommended tune: Christine McAskill

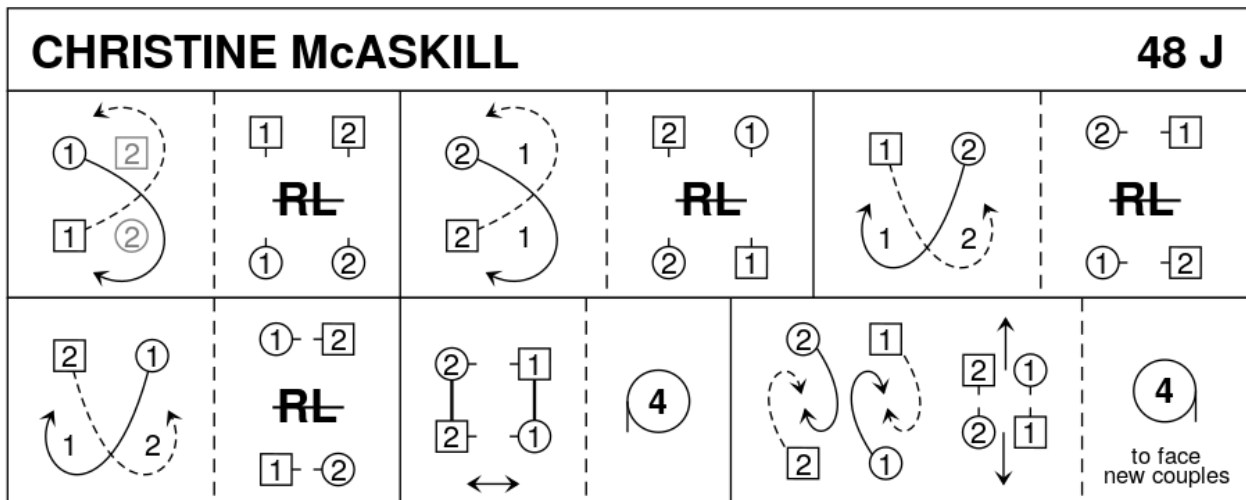

Churchill Barracks

A forty bar Reel for two couples, in a longwise set.
 First couple cross to the opposite side on the second chord.

- 1-4 First and second couples face up and down. Men slip to their right and ladies slip to their left to cross to the opposite side of the set, ladies passing in front of their partners. All set.
- 5-8 Ladies slip to their right and men to their left to cross back to original side. All set.
- 9-16 First and second couples dance rights and lefts, giving right hands on the sides to commence.
- 17-20 Four hands round to the left in a circle.
- 21-22 First couple dance down under an arch made by second couple.
- 23-24 Second lady turns to her left to dance under an arch made by second couples nearer hands, whilst her partner dances round to the right, they finish between first couple facing down the room.
- 25-32 First and second couples dance down the middle and back in line.
- 33-40 First and second couples dance a reel of four across the set, passing by the right shoulder to commence. On the last two bars second couple lead up into first place on own side whilst first couple finish in second place.

Repeat from second place.
 Recommended tune: Churchill Barracks

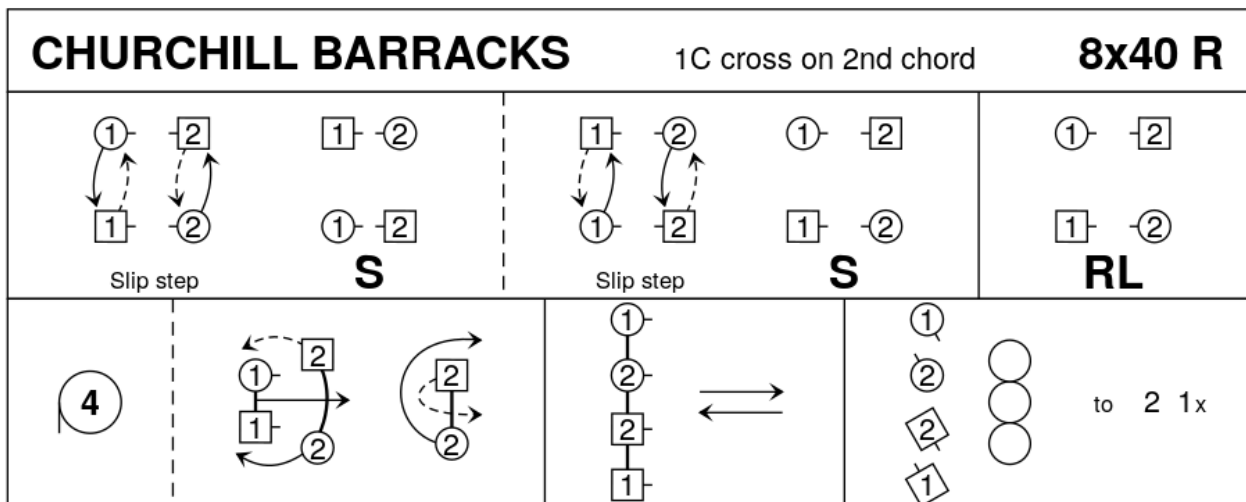

Clarence House

A thirty-two bar Reel for four couples in a longwise set.

- 1-4 First couple lead down between second couple and cast off behind third place into fourth place, whilst fourth couple lead up between third couple and cast up into first place. At the same time second couple cast up into first place and cross over into second place on the opposite side, whilst third couple cast off into fourth place and cross up into third place on the opposite side. Second and third couples finish facing out.
- 5-8 Second and fourth couples dance half a double figure of eight across the set, second couple cast up and fourth couple cross to commence. Third and first couples do the same, third couple casting off whilst first couple cross. Second and third couples finish facing out, first couple face up and fourth couple face down.
- 9-12 First and fourth ladies turn one and a half times with the right hand to change places, first and fourth men do the same. Meanwhile second couple cast up and cross over giving right hand, whilst third couple cast off and cross giving right hand.
- 13-14 Second couple cast off, third couple cast up and first and fourth couples set.
- 15-16 All cross back to own side giving left hand, to finish with both hands joined with partner ready for a poussette.
- 17-24 First and second couples poussette, third and fourth couples likewise: fourth couple finish in second place and first couple finish in third place.
- 25-32 All dance eight hands round in a circle to the left and back to the right.

Repeat with new top couple.

Recommended tune: Clarence House

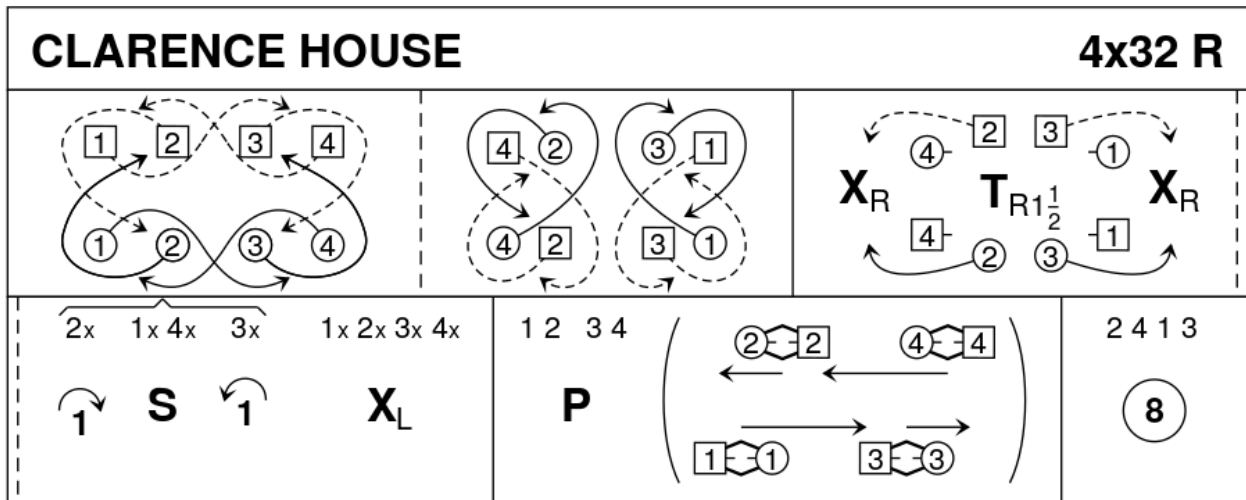

C. M. Beattie

A thirty-two bar Reel for three couples in a longwise set.

- 1-8 First couple turn with the right hand, cast off into second place and turn with the left hand one and a quarter times to finish facing first corners.
- 9-12 Turn first corners with the right hand to finish facing first corner's partner.
- 13-16 First lady dances a half reel of three across the set with second couple, passing second lady by the left shoulder to commence. Meanwhile first man dances a half reel of three across the set with third couple, passing third man by the left to commence.
- 17-20 First lady turns second lady with the right hand to finish facing second man. Meanwhile first man turns third man with the right hand to finish facing third lady.
- 21-24 First lady passes second man by the left shoulder to dance half a reel of three across the set. Meanwhile first man passes third lady by the left shoulder to dance half a reel of three across the set. First couple finish facing up and down the set, lady between second couple and man between third couple.
- 25-32 First couple set and change places giving left hand; first man dances up to the top and casts off behind second man into second place on own side whilst first lady dances below third lady and casts up behind third lady into second place on own side.

Repeat from second place.

Recommended tune: C. M. Beattie

C. M. BEATTIE				8x32 R			
T_R 1	$T_{L1\frac{1}{4}}$	T_R		2 ③ ① ① T_R ② 3		2 3 ①-① 2 3 S X_L	

The Cockle Gatherers

A thirty-two bar Reel for three couples in a longwise set.

- 1-8 First and second couples dance a reel of four, to commence first lady and second man dance in passing by the left shoulder; to finish first man and second lady do not pass by the left shoulder, instead dancing over to own side directly. First couple finish in second place.
- 9-12 First and second couples dance right hands across in a wheel.
- 13-16 First and third couples dance left hands across in a wheel.
- 17-32 Second and third couples dance an interrupted rights and lefts: they set and change places on the sides giving right hands, set and cross over giving left hands, then repeat these eight bars back to place. Meanwhile first man followed by his partner: casts off behind fourth corner position, dances up to the top, casts off behind third corner position, crosses over to the opposite side, casts up behind second corner position, dances down the middle, casts up behind first corner position and crosses back to second place on own side.

Repeat from second place.

Recommended tune: The Cockle Gatherers

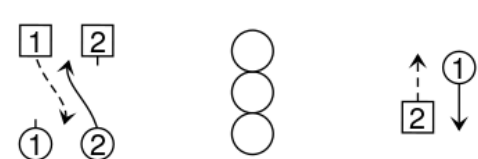
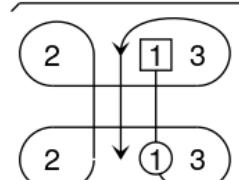
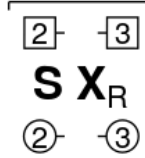
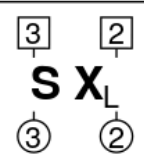
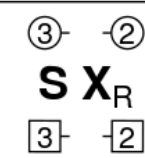
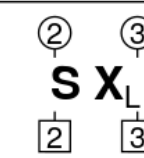
THE COCKLE GATHERERS			8x32 R	
	2 1 RA	1 3 LA		
<div style="display: flex; justify-content: space-between; align-items: center;"> <div style="text-align: center;">  <p>16 bars</p> </div> <div style="text-align: center;">  <p>SX_R</p> </div> <div style="text-align: center;">  <p>SX_L</p> </div> <div style="text-align: center;">  <p>SX_R</p> </div> <div style="text-align: center;">  <p>SX_L</p> </div> </div>				

The Coffee Leaf

A forty bar Reel for four couples in a longwise set.

- 1-4 All four couples join both hands with partner and dance down the middle with eight slip steps.
- 5-8 First couple make an arch with both hands; second, third and fourth couples dance up the middle under the arch with eight slip steps.
- 9-10 Second couple cast off behind third couple who slip up into first place, whilst fourth couple slip up into third place.
- 11-12 Second couple join both hands and slip into third place whilst fourth couple cast up into second place. Second and third couples finish facing out.
- 13-16 Third, fourth, second and first couples dance a half a reel of four on own side of the set. Ladies pass right shoulders to commence whilst the men pass left shoulders to commence.
- 17-18 All set.
- 19-20 First couple cast off into second place and fourth couple cast off into fourth place, second and third couples step up.
- 21-24 First and third couples dance right hands across in a wheel.
- 25-32 First and third couples change places with the knot.
- 33-36 Third and first couples dance left hands across in a wheel.
- 37-38 First couple cast off into fourth place.
- 39-40 All set.

Repeat with new top couple.

Recommended tune: The Coffee Leaf

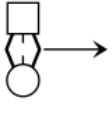
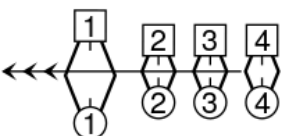
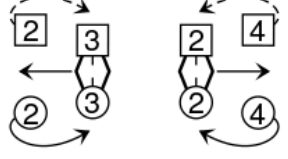
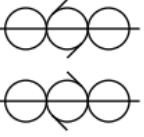
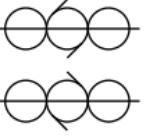
THE COFFEE LEAF					4x40 R	
1 2 3 4 	 make arch				3 4 2 1 	
1 2 4 3 1 4 S ↻ 1	1 3 RA	1 3 KNOT	3 1 LA	2 3 4 1 ↻ S		

Collie's Reel

A one hundred and ninety-two bar Reel for four couples in a square set.

First Figure

- 1-8 All four couples dance eight hands round to the left in a circle and back to the right.
- 9-16 All four couples set twice to partner; then turn with the right hand one and a quarter times.
- 17-18 The men dance left hands across in a wheel half way.
- 19-22 The men collect the opposite lady on their right and continue to dance left hands across in a wheel half way, to leave the ladies on the opposite side of the set.
- 23-24 Men dance left hands across in a wheel half way.
- 25-28 The men dance round their partners in a clockwise circle.
- 29-32 All promenade anticlockwise around the set half way to original places.

Second figure

- 1-4 First couple lead between third couple and separate, the man casts behind third lady and second man to finish between second couple whilst the lady casts behind third man and fourth lady to finish between fourth couple.
- 5-8 First couple, with second and fourth couples, advance and retire.
- 9-14 First couple dance in and meet, lead between third couple and separate; first man casts behind third lady and second couple to original place whilst first lady casts behind third man and fourth couple to original place.
- 15-16 First couple turn with the right hand.
- 17-20 All turn corner with the left hand.
- 21-24 All dance back to back with partner.
- 25-32 All dance a grand chain, one step to each hand.

The second figure is then repeated, with second couple taking the lead on bars 1-16.
Third couple repeat and fourth couple repeat.

Third figure

- 1-8 All dance eight hands round to the left in a circle and back to the right.
- 9-16 All set twice to partner; then turn partner with the left hand one and a quarter times.
- 17-18 The ladies dance right hands across in a wheel half way.
- 19-22 The ladies pick up the opposite man in their left hands and all dance right hands across in a wheel half way to bring the men to the opposite position.
- 23-24 The ladies dance right hands across in a wheel half way.
- 25-28 The ladies dance round their partners in an anticlockwise circle.
- 29-32 All promenade half way round the set in a clockwise circle.

Recommended tune: Collie's Reel

(diagram on next page)

COLLIE'S REEL				192 R
1st figure				
				<p style="text-align: center;">2nd figure</p>
<p style="text-align: center;">T_R 2 bars</p>		<p style="text-align: center;">T_L</p>		<p style="text-align: center;">D</p>
2	3	4	<p style="text-align: center;">3rd figure</p>	
R	R	R		
2nd figure	2nd figure	2nd figure		

Colonel Byng

A thirty-two bar Strathspey for four couples in a longwise set.

- 1-4 First and second couples dance right hands across in a wheel, third and fourth couples do the same.
- 5-8 All four couples dance a half a reel of four on own side of the set.
- 9-16 Grand chain for four couples, giving right hands on the sides to commence, one step to each hand.
- 17-24 First couple make an arch. Fourth couple, followed by third and second couples cast off below first couple and lead up under the arch; fourth couple dance out into third place and make an arch, third couple dance between fourth couple into second place and make an arch, second couple dance up into first place.
- 25-26 All set Highland Schottische with the right foot only.
- 27-28 All cross over giving left hand to partner in passing and commencing to travel on the left foot.
- 29-30 All set Highland Schottische with the left foot only.
- 31-32 All cross over giving right hand to partner in passing.

Repeat with new top couple.
 Recommended tune: Colonel Byng

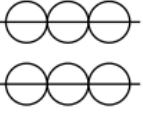
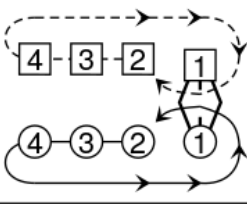
COLONEL BYNG		4x32 S	
1 2 3 4 RA	1 2 3 4 	4- 3- 2- 1- CHAIN 4- 3- 2- 1-	
2 3 4 1	2 3 4 1	2x 3x 4x 1x	2x 3x 4x 1x
HS_R	X_L left foot	HS_L	X_R

Colosseum

A thirty-two bar Reel for two couples in a longwise set.

- 1-4 First lady and second man set and turn with the right hand.
- 5-8 First man and second lady set and turn with the left hand. Meanwhile first lady and second man dance round just over half way in a clockwise circle to finish facing own partner in a line across the dance, first man and second lady back to back in the centre.
- 9-16 First and second couples dance a reel of four across the set. Finish with first couple on the men's side of the set and second couple on the ladies' side of the set with the ladies in first place. Second lady and first man omit left shoulder pass on bar 16 to dance out to the side lines.
- 17-18 All dance one place clockwise in a chase to original places.
- 19-22 All dance right hands across in a wheel.
- 23-24 First couple cast off into second place, second couple lead up to first place.
- 25-32 Second and first couples dance rights and lefts.

Repeat from second place.
 Recommended tune: Colosseum

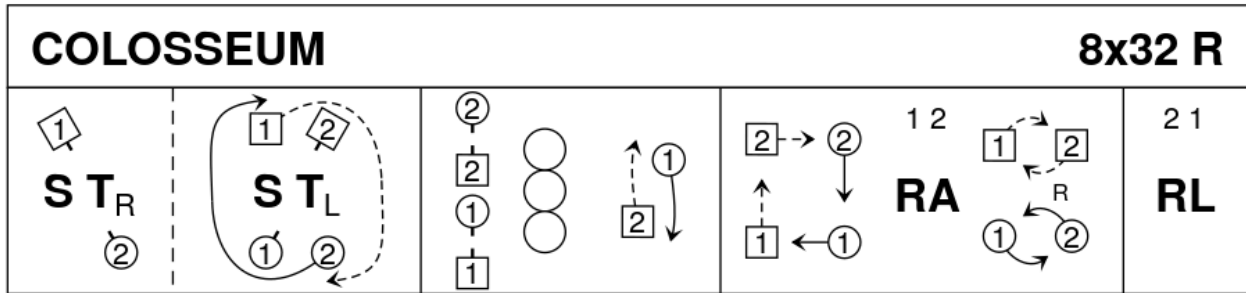

The Conversazione

A thirty-two bar Strathspey for three couples in a longwise set.

- 1-8 First couple set, cross over giving right hand in passing; cast off into second place and turn with the left hand to finish facing first corners. Second couple step up on bars five and six.
- 9-16 First couple set to and turn corners with both hands, to finish in second place on opposite sides.
- 17-24 Second and first couples dance rights and lefts.
- 25-32 First couple cross over giving right hand, cast off behind third couple, turn with the left hand and cast up into second place.

Repeat from second place.

Recommended tune: The Conversazione

THE CONVERSAZIONE					8x32 S	
S X_R	1 ↻ T_L	S T_B	↻ S ↻ T_B	2 1x RL	1x X_R 1 ↻	T_L ↻ 1



Cropie's Strathspey

A thirty-two bar Strathspey for three couples in a longwise set.

- 1-4 First man and second lady set and turn with the right hand.
- 5-8 First lady and second man set and turn half way with the left hand to finish back to back with second man facing the top of the set and first lady facing down. At the same time first man and second lady dance half way round their partners in a clockwise circle to finish facing own partner.
- 9-16 Second and first couples dance a reel of four to finish on own side of the set, first couple in second place.
- 17-18 First couple cross over giving right hand.
- 19-20 First man turns second lady with the left hand whilst first lady turns second man with the right hand.
- 21-24 First and third couples dance half rights and lefts, first couple finish in third place on own side, third couple finish back to back facing first corner position.
- 25-32 Third couple turn corner, partner, corner, partner.

Repeat with new top couple.

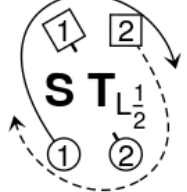
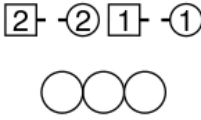
Recommended tune: Cropie's Strathspey

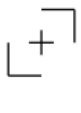
CROPIE'S STRATHSPEY				3x32 S		
 <p>ST_R</p>	 <p>ST_L^{1/2}</p>		 <p>X_R</p>	 <p>T_L</p>	<p>1x3</p> <p>RL</p>	<p>3</p> 

Dawning of the Day

A thirty-two bar Reel for trios (each comprising a man and two ladies, one on either side of the man) in a circle round the room.

- 1-4 All advance and retire.
- 5-8 Man sets to the lady on his right and turns her with both hands.
- 9-12 All advance and retire.
- 13-16 Man sets to the lady on his left and turns her with both hands.
- 17-24 Man passes his right hand partner by the left shoulder to dance a reel of three with his partners.
- 25-28 All advance for four steps and turn right about to face in the opposite direction. The man takes the right hand of the lady on his right in his right hand, and the left hand of the lady on his left in his left hand the ladies join their other hands behind his back.
- 29-32 All advance for two steps, the ladies release the hand joined behind the man's back and on the next step turn inwards, to face in the opposite direction, releasing the man's hands. The man continues to advance turning on the last step between the next two ladies round the circle, whilst the ladies on the last step advance in the opposite direction to meet the next man.

Repeat with new partners.

Recommended tune: Dawning of the Day

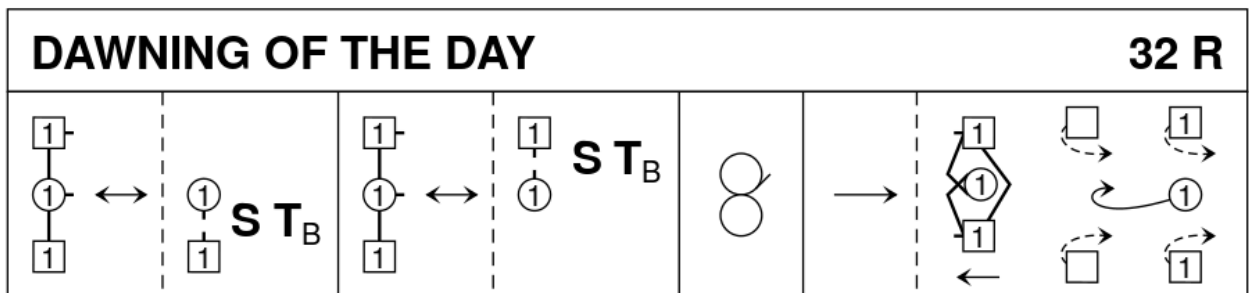

David Ross

A thirty-two bar Reel for three couples in a longwise set.

- 1-8 First couple set, turn with the right hand one and a half times and cast off into second place on the opposite side second couple step up.
- 9-16 Six hands round in a circle to the left and back to the right.
- 17-24 First couple set, turn with the left hand one and a half times and cast off into third place on own side, third couple step up.
- 25-32 Grand chain for three couples, to commence first couple cross over giving right hand whilst second and third couples change places on the sides giving right hands.

Repeat with new top couple.

Recommended tune: David Ross

DAVID ROSS			3x32 R
S T _{R1½} ↻ 1	2 1x3 (6)	S T _{L1½} ↻ 1	<div style="display: flex; justify-content: space-around; font-size: 1.2em;"> 2 3 1 </div> <p style="margin: 5px 0;">CHAIN</p> <div style="display: flex; justify-content: space-around; font-size: 1.2em;"> 2 3 1 </div>

John W Mitchell, Whetherly Book 4

3C/3C longwise set.

Davie's Brae



A thirty-two bar Jig for four couples in a longwise set.

On the second chord third and fourth couples cross to the opposite side of the set.

- 1-4 First and second couples dance half rights and lefts, third and fourth couples do the same.
- 5-8 All four couples set and turn with the right hand, second and first couples finish facing down the set, third and fourth couples finish facing up.
- 9-16 First and second couples dance an allemande, third and fourth couples do the same.
- 17-20 First and second couples dance half rights and lefts, third and fourth couples do the same.
- 21-24 First and fourth couples dance half rights and lefts.
- 25-32 First and fourth couples dance a ladies' chain.

Repeat with new top couple.

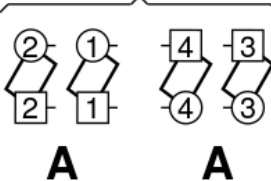
Recommended tune: Davie's Brae

DAVIE'S BRAE		3C & 4C cross on 2nd chord	4x32 J		
1 2 3x 4x	2x 1x 4 3		1x 2x 3 4	1 4x	4 1x
RL	S T_R	A A	RL	RL	

Dornachd Head

A thirty-two bar Jig for five couples in a longwise set.

- 1-8 First couple dance down the middle and back, beneath arches made by second, third, fourth and fifth couples.
- 9-16 Promenade: first, third and fifth couples dance up to the top, down the men's side and up to place; second and fourth couples dance up to the top, down the ladies' side and lead up to original places, but cross over on the last bar to finish facing first corners.
- 17-24 Second and fourth couples turn corner, partner, corner, partner.
- 25-32 First couple followed by second, third, fourth and fifth couples cast off to the foot of the dance. First couple lead up to fourth place and make an arch, second couple stop in fifth place and make an arch, third couple followed by fourth and fifth couples lead up the middle under the arches to finish with third couple in first place.

Repeat with new top couple.

Recommended tune: Davie's Brae

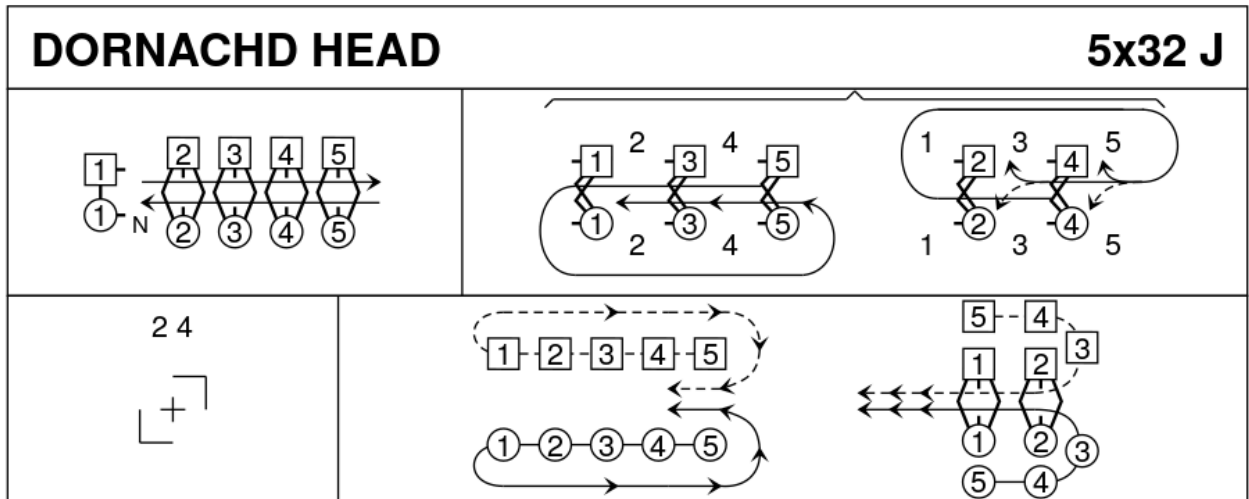

Edward Jay's Jaunt

A thirty-two bar Reel for three couples in a longwise set.

- 1-4 First man dances a half reel of three across the set with second couple.
- 5-8 First couple take a promenade hold and commence to dance a half reel of three across the set with second couple. On bars 7 & 8 first man casts off below third man whilst first lady completes the reel.
- 9-12 First man dances a half reel of three with third couple, across the set, meanwhile first lady on bars 9 & 10 crosses down between second couple to join her partner to take a promenade hold to complete the half reel.
- 13-16 First couple commence to dance a half reel of three with third couple, on bars 15 & 16 first man leaves his partner and casts up behind second man, whilst first lady completes the half reel. first couple finish facing up and down the dance, men between second couple and lady between third couple.
- 17-20 All three couples advance and retire, up and down the set.
- 21-24 First couple change places giving left hand in passing. First man casts round third lady into second place on the ladies' side whilst first lady casts round second man into second place on the man's side.
- 25-28 All three couples advance and retire, across the set.
- 29-32 First couple turn with the left hand one and a half times to own side of the set.

Repeat from second place.

Recommended tune: Edward Jay's Jaunt

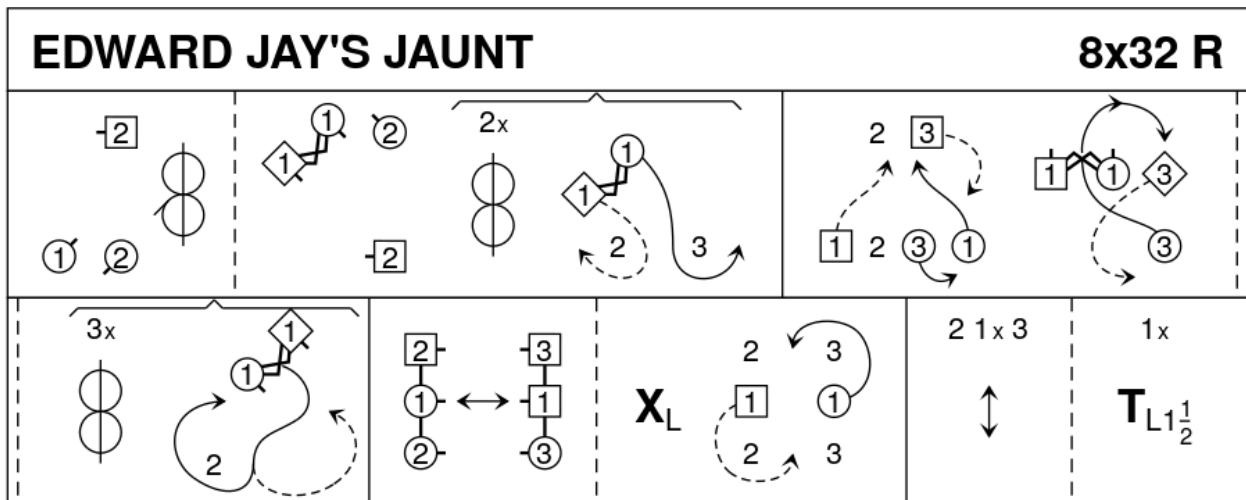

Ellen Richard's Delight

A two hundred and fifty-six bar Jig for four couples in a square set.

First figure

- 1-4 Men dance right hands across in a wheel half way.
- 5-8 Half reels of four on the sides of the square. Men dance round their corner lady passing by the right, ladies the same, then each pass person on the same side (their original opposite) passes by the left shoulder to change places.
- 9-12 Ladies dance right hands across in a wheel.
- 13-16 Repeat half reels of four on the sides of the square, finishing alongside partner on the opposite side of the set.

Chorus: to be repeated after each figure

- 1-2 Eight hands round to the left.
- 3-4 Dance four back steps.
- 5-6 Eight hands round to the right.
- 7-8 Assemble and dance three spring changes.
- 9-10 Eight hands round to the right.
- 11-12 Four back steps.
- 13-14 Eight hands round to the left.
- 15-16 Assemble and three spring changes.

Second figure

- 1-4 Men dance left hands across in a wheel to finish back to back in the centre facing own partner.
- 5-12 All dance a double reel of four, giving left hands across half way in passing in the middle.
- 13-16 All turn with the right hand one and three quarter times to finish on side lines.

Third figure

- 1-4 Ladies dance right hands across in a wheel to finish back to back in the centre facing own partner.
- 5-12 All dance a double reel of four commencing by passing partner by the left shoulder and giving right hands across half way in passing in the middle.
- 13-16 All turn partner with the left hand one and three quarter times to finish on the sidelines.

Fourth figure

- 1-8 Ladies dance a double ladies' chain: give right hands across half way to turn the opposite man, then give right hands across half way to turn own partner; men dance along sidelines to commence.
- 9-16 Men dance a double men's chain: men give left hands across half way to turn the opposite lady, then give left hands across half way to turn own partner; ladies dance along the sides to commence.

Fifth figure

- 1-4 First and third couples set to partner and turn three quarters with the right hand.
- 5-8 First and third couples dance a half reel of four to finish in original places.
- 9-16 Second and fourth couples repeat bars 1-8.

Sixth figure

- 1-4 Men dance right hands across in a wheel.
- 5-8 Men dance half round to the opposite side of the set. i.e. cast behind the lady on their left and then cast behind the lady opposite their commencing positions.
- 9-16 Repeat bars 1-8.

Seventh figure

- 1-4 Ladies dance left hands across in a wheel.
- 5-8 Ladies dance half round to the opposite side of the set. i.e. cast behind the man on their right and then cast behind the man opposite their commencing positions.
- 9-16 Repeat bars 1-8.

Eighth figure

- 1-16 Schiehallion reels.

Recommended tune: Ellen Richard's Delight

(diagram on next page)

ELLEN RICHARD'S DELIGHT				256 J	
Figure 1 ○ RA			□ RA		
Chorus	ALL 8 Back Step 2 bars	ALL 8 Assemble + 3 Spring Changes 2 bars	ALL 8 Back Step 2 bars	ALL 8 Assemble + 3 Spring Changes 2 bars	
Figure 2 ○ LA				ALL T _{R1³/₄}	R Chorus
Figure 3 □ RA				ALL T _{R1³/₄}	R Chorus
Figure 4 		R Chorus	Figure 5 4 4 S T _{R³/₄} 2 2	3 1 	4 2 R Chorus
Figure 6 ○ RA			○ RA		R Chorus
Figure 7 □ LA		□ LA		R Chorus	Figure 8 Schiehallion Reel
					R Chorus 16 bars

Eriskay Boat

A thirty-two bar Reel for three couples in a longwise set of five couples.

- 1-4 First lady and second man set and change places giving right hand in passing.
- 5-8 First man and second lady set and turn with the left hand to finish back to back facing own side of the set. Meanwhile their partners dance half way round the outside to finish on own side of the set, first lady facing second lady and second man facing first man.
- 9-16 First and second couples dance a reel of four, first couple finish in second place. First man and second lady omit the last left shoulder pass, to dance out to own side.
- 17-24 First and second couples dance right hands across in a wheel and back with the left hand.
- 25-32 First and third couples dance rights and lefts.

Repeat from second place, on the next repeat new top couple commences and original top couple repeats from third place.

Recommended tune: Eriskay Boat

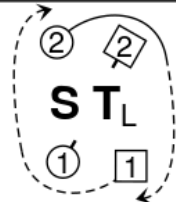
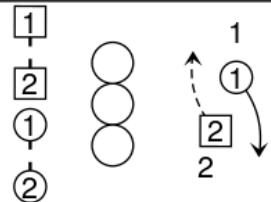
ERISKAY BOAT			10x32 R		
			<p>2 1</p> <p>RA</p>	<p>2 1</p> <p>LA</p>	<p>1 3</p> <p>RL</p>
<p>1st repeat: 1C dance from 2nd place</p> <p>2nd repeat: Couples in 1st and 3rd places start (original 2C & 1C)</p>					

Appendix to the new edition: Description of Formations

For ease of reference, all formation descriptions which originally appeared spread throughout the book have been collected here.

Quern progression

Quern for two couples:

- 1-3 First and second couples turn partner with the right hand once round.
- 4-6 First and second couples dance right hands across in a wheel half way.
- 7-8 Second and first couples cross back to own side giving right hand in passing.

This should be danced as a continuous flowing movement in the middle of the set dancers should not return to the side lines at the end of bar 3 or bar 6. After joining hands on bar 1 they should be retained until bar 8 when they will be released during the crossing back to own side of the set.

Quern for three couples:

- 1-3 All three couples turn partner with the right hand.
- 4-6 All three couples dance six hands across in a right hand wheel half way.
- 7-8 All three couples cross back to own side giving right hand in passing.

This should be danced as a continuous flowing movement as described for the two couple quern above.

Version History

- 1.00 / 2020-06-22 First re-published version.
- 1.01 / 2020-07-15 “Anne Frasier McKenzie”: typo on bar count; was “53” instead of “33”.
“Anne Eltham’s Fancy”: The corrected version in 1.00 wasn’t working. New bars 1-8 have been introduced, diagram has been changed accordingly.
“Ainster Fisherman”: the new editor’s note specifies the phrasing of the last 8 bars without changing the dance description itself.